

USERS MANUAL

COMPACT N SERIES DEHUMIDIFIER

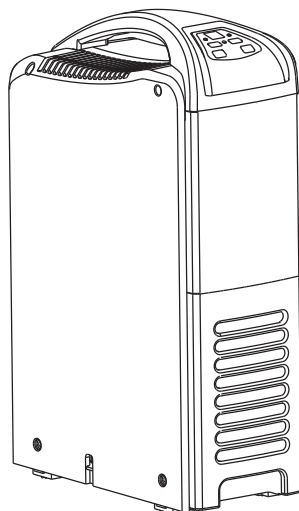

Models

ECO8LDN
ECO10LDN
ECO12LDN

Read This Manual

Inside you will find many helpful hints on how to use and maintain your dehumidifier properly. Just a little preventative care on your part can save you a great deal of time and money over the life of your dehumidifier. You'll find many answers to common problems in the chart of troubleshooting tips. Review the chart of Troubleshooting Tips before calling your service engineer.

RESPONSIBLE DISPOSAL & RECYCLING

When your appliance reaches the end of its life, please dispose responsibly.

DO NOT: You must not dispose this appliance as unsorted waste or with your domestic household waste. Please observe local regulations for disposal.

- Most local authorities have specific collection systems for appliances where disposals are free of charge to the end user.
- When replacing an existing appliance with a new appliance, your retailer may take back the old appliance for disposal.

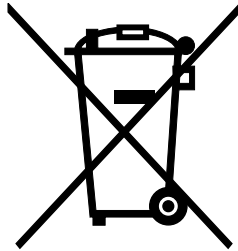

CONTENTS

SAFETY PRECAUTIONS

Warning	2
Caution	2
Electrical information	3

DEHUMIDIFIER CONTROL PANEL

Control panel and features.....	4
---------------------------------	---

IDENTIFICATION OF PARTS

Identification of parts	5
-------------------------------	---

OPERATING THE UNIT

Positioning the unit & using the unit	6
Removing the collected water	7

CARE AND MAINTENANCE

Care and cleaning the dehumidifier	8
Optional Filter - Hepa & Carbon Filter	9



TROUBLESHOOTING TIPS

Troubleshooting tips	10
----------------------------	----



SAFETY PRECAUTIONS

To prevent injury to the user or other people and property damage, the following instructions must be followed. Incorrect operation due to ignoring of instructions may cause harm or damage.

■ The seriousness is classified by the following indications.

 WARNING	This symbol indicates the possibility of death or serious injury.
 CAUTION	This symbol indicates the possibility of injury or damage to property.

■ Meanings of symbols used in this manual are as shown below.

	Never do this.
	Always do this.

⚠ WARNING

⊘ Do not exceed the rating of the power outlet or connection device.

- Otherwise, it may cause electric shock or fire due to excess heat generation.

⊘ Do not start or stop the unit by switching on or off the power.

- It may cause electric shock or fire due to heat generation.

⊘ Do not damage or use an unspecified power cord.

- It may cause electric shock or fire.

⊘ Do not modify power cord length or share the outlet with other appliances

- It may cause electric shock or fire due to heat generation.

⊘ Do not insert or pull out plug with wet hands.

- It may cause electric shock.

⊘ Do not place the unit near a heat source.

- Plastic parts may melt and cause a fire.

Ⓜ Disconnect the power if strange sounds, smell, or smoke comes from it.

- It may cause fire and electric shock.

⊘ You should never try to take apart or repair the unit by yourself.

- It may cause failure of machine or electric shock.

Ⓜ Before cleaning, turn off the power and unplug the unit.

- It may cause electrical shock or injury.

⊘ Do not use the machine near flammable gas or combustibles, such as gasoline, benzene, thinner, etc.

- It may cause an explosion or fire.

⊘ Do not drink or use the water drained from air conditioner.

- It contains contaminants and could make you sick.

⊘ Do not open the unit during operation.

- It may cause electric shock.

⚠ CAUTION

Ⓜ When using in closets or other small spaces, be sure to keep doors open.

- Lack of ventilation can cause overheating and fire.

⊘ Do not put in places where water may splash onto the unit.

- Water may enter the unit and degrade the insulation. It may cause an electric shock or fire.

Ⓜ Place the unit on a level, sturdy section of the floor.

- If the unit falls over, it may cause water to spill and damage belongings, or cause electrical shock or fire.

SAFETY PRECAUTIONS

⚠ CAUTION

⊘ Do not cover the intake or exhaust openings with cloths or towels.

- A lack of air flow can lead to overheating and fire.

⊘ When the unit is to be cleaned, switch off, and turn off the circuit breaker.

- Do not clean unit when power is on as it may cause fire and electric shock, it may cause an injury.

⊘ Always insert the filters securely. Clean filter once every two weeks.

- Operation without filters may cause failure.

⊘ Care should be taken when using the unit in a room with the following persons:

- Infants, children, elderly people, and people not sensitive to humidity.

⊘ Do not place heavy object on the power cord and take care so that the cord is not compressed.

- There is danger of fire or electric shock.

⊘ If water enters the unit, turn the unit off and disconnect the power, contact a qualified service technician.

- It may cause failure of appliance or accident.

⊘ Do not use in areas where chemicals are handled.

- This will cause the unit deterioration due to chemicals and solvents dissolved in the air.

⊘ Do not climb up on or sit on the unit.

- You may be injured if you fall or if the unit falls over.

⊘ Do not place flower vases or other water container on top of the unit.

- Water may spill inside the unit, causing insulation failure and electrical shock or fire.

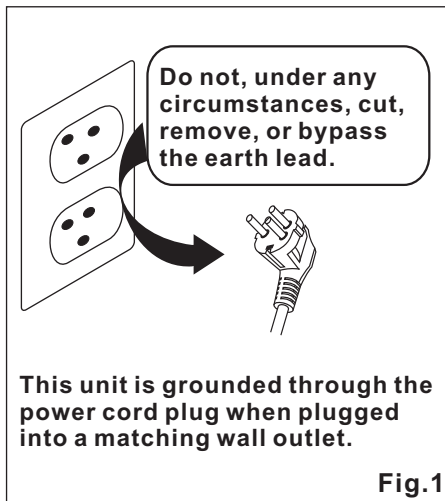

Electrical Information

- The manufacturer's nameplate is located on the rear panel of the unit and contains electrical and other technical data specific to this unit.
- The dehumidifier must be properly earthed. To minimize shock and fire hazards, proper earthing is important. The power cord is equipped with a three-pin plug for protection against shock hazards.
- Your dehumidifier must be used in a properly grounded wall receptacle. If the wall receptacle you intend to use is not adequately grounded or protected by a time delay fuse or circuit breaker, have a qualified electrician install the proper receptacle.
- Ensure the receptacle is accessible after the unit installation.
- **Do not use extension cords or an adapter plugs with this unit.** However, if it is necessary to use an extension cord, use a sufficiently rated extension and ensure cord is fully unwound to avoid heat build-up.
- To avoid the possibility of personal injury, always disconnect the power supply to the unit, before installing and/or servicing.

DEHUMIDIFIER CONTROL PANEL

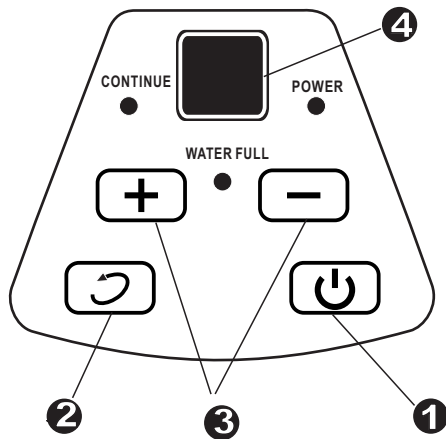

Fig.2

Control buttons

① POWER

Press to turn the dehumidifier on and off. The power indicator light blinks slowly when the power is first connected but the unit is off. It illuminates (green) when the power button is pressed and the dehumidifier is switched on. If the Humidity/Temperature sensor malfunctions it blinks rapidly (several times a second).

② Continuous operation

When pressed the continue light is illuminated and the dehumidifier will operate continuously for continuous dehumidification whatever the humidity. The Humidity set buttons cannot be used when Continuous operation is on.

③ Humidity Setting Control

The humidity level can be set within a range of 35%RH(Relative Humidity) to 80%RH(Relative Humidity) in 5% increments.

For drier air, press the ⊖ pad and set to a lower percent value(%).

For damper air, press the ⊕ pad and set a higher percent value(%).

The machine will then turn on and off automatically to maintain the selected level.

④ Display

Shows the setting control % humidity level while adjusting, then shows the actual room % humidity level (+/- 5% accuracy) .

Error Codes:

E1- Humidity sensor error--Unplug the unit and plug it back in. If error repeats, call for service.

E2- Temperature sensor error-- Unplug the unit and plug it back in. If error repeats, call for service.

P1- Unit is defrosting-- Allow the unit time to automatically defrost. The error will clear after the unit self defrosts.

P2- Bucket is full-- Empty the bucket and replace in the right position - the error will reset after a few seconds.

NOTE: When more than one errors occur, the priority of the code display order is:

P2--E2--E1--P1.

Other indicators & features of the dehumidifier

Water Full Light

Glows when the water bucket is full, whilst the bucket is removed and if the bucket is not replaced in the proper position.

The water level control float stops the dehumidifier when the bucket is full, or when the bucket is removed or not replaced in the proper position.

Auto Defrost

When frost builds up on the evaporator coils, the compressor will cycle off and the fan will continue to run until the frost disappears.

Wait 3 minutes before resuming operation

After the unit has stopped (other than tank full), it will not restart for approx. 3 minutes. This is to protect the unit and is not a fault. Operation will automatically restart after 3 minutes.

Auto-Restart after power interruption

If the power is interrupted to the unit then when it comes back on the machine will restart automatically in the same mode as was set prior to the power outage.

IDENTIFICATION OF PARTS

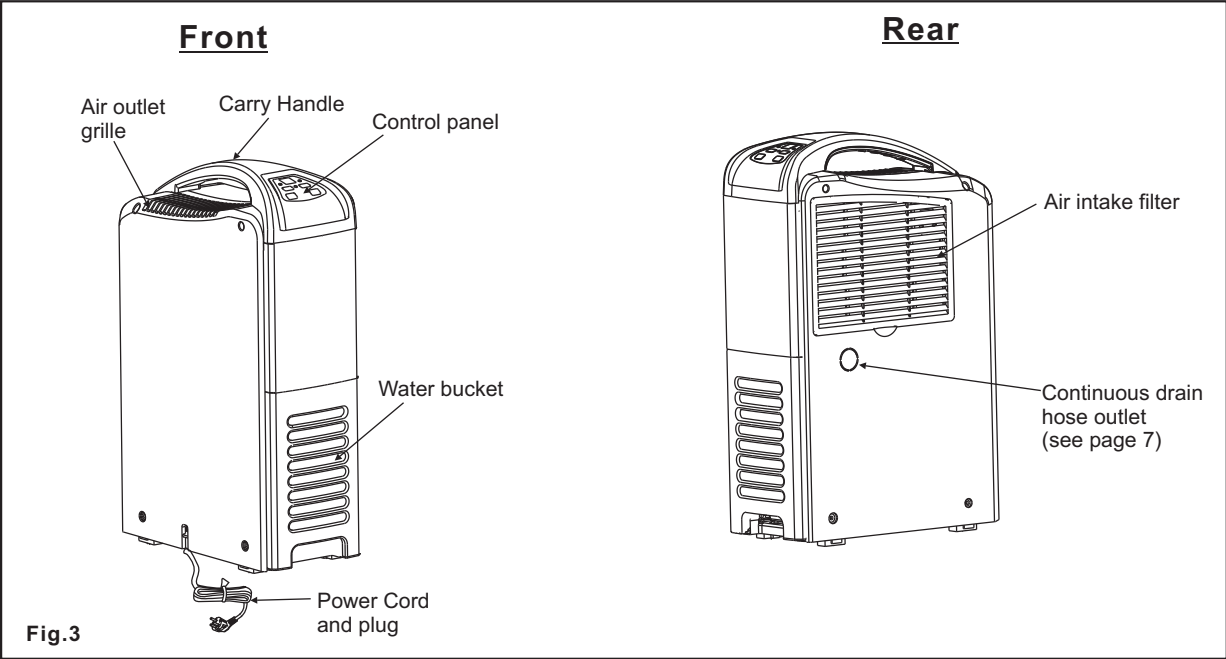

OPERATING THE UNIT

Positioning the unit

- Do not use outdoors.
- This dehumidifier is intended for indoor residential applications only. This dehumidifier should not be used for commercial or industrial applications.
- Place the dehumidifier on a smooth, level floor, strong enough to support the unit with a full bucket of water.
- Allow at least 20cm of air space on all sides of the unit for good air circulation.
- Place the unit in an area where the temperature will not fall below 5°C (41°F). The coils can become covered with frost at temperatures below 5°C (41°F), which may reduce performance or cause the machine to ice-up and leak.
- Place the unit away from any heater or radiator.
- The dehumidifier is best operated in an enclosed area to be most effective.
- Closing doors, windows and other outside openings will improve the efficiency of the dehumidification process.

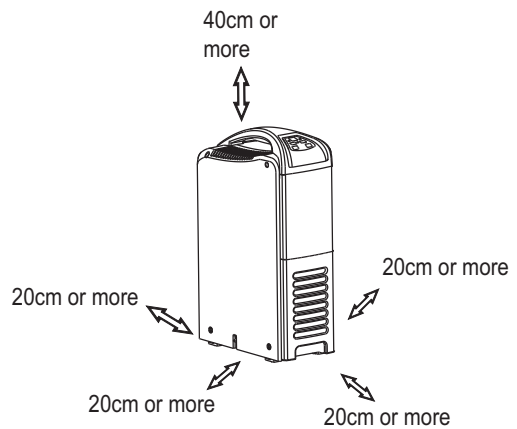

Fig.4

Using the unit

- Select a suitable location, making sure you have easy access to an electrical outlet.
- Plug the unit into a 220 - 240V ~ 50Hz electrical power socket. The electrical socket-outlet must be fitted with an earth connection.
- Make sure the water bucket is correctly and fully inserted otherwise the unit will not operate properly.
- When first using the dehumidifier, operate the unit continuously for 24 hours.
- This unit is designed to operate within a working environment between 5°C and 35°C.
- If the unit has been switched off and needs to be switched on again quickly, allow approximately three minutes for the correct operation to resume.
- Do not connect the dehumidifier to a multiple socket outlet, which is also being used for other electrical appliances.

Removing the collected water

There are two ways to remove collected water.

1. Using the bucket

- When the bucket is full, the unit will automatically stop running the water full light will flash and the display will show P2.
- Slowly pull out the bucket. Use the handgrip at the bottom of the tank and carefully pull out straight so water does not spill. Do not put the tank on the floor because the bottom of the bucket is uneven and it might spill.
- Throw away the water and replace the bucket. The bucket must be in place and securely seated for the dehumidifier to operate.
- The machine will re-start after a few seconds when the bucket is correctly inserted.

NOTES:

- Be sure to push the bucket gently all the way into the unit. Forcing the bucket back into the machine may cause damage to the tank or the unit.

2. Using continuous drainage

If you are leaving the unit for long periods then it may be beneficial to drain the water away continuously. This can be done by inserting a pipe onto the machine.

- Cut out the plastic blanking plug located on the side of the machine (see picture on right). Attach a drain hose (16mm internal diameter) and lead it out, downhill and away from the unit.

NOTE: The continuous drainage hose must go downhill all the way from the unit as the water has to drain away by gravity. Do not place any part of the hose higher than the outlet of the machine or the water will not drain away and internal damage could occur to the unit.

1. Pull out the bucket a little.

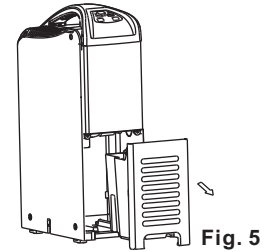

Fig. 5

2. Hold the bottom of the bucket with one hand and pull gently backwards then up to remove.

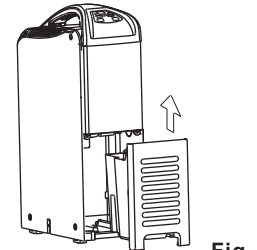
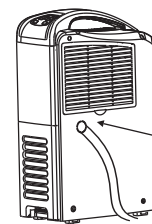

Fig. 6

3. Pour the water out and replace.



Cut out the plastic cover, then push the hose onto the drain hose outlet that is behind it.

Fig. 7

Care and cleaning of the dehumidifier

Turn the dehumidifier off and remove the plug from the wall outlet before cleaning.

1. Clean the Grille and Case

- Wipe the unit with a cloth using water and a mild detergent. Do not use bleach or abrasives.
- Do not splash water directly onto the unit. Doing so may cause internal damage to the unit.
- The air intake and outlet grilles get dusty quite easily, so use a vacuum attachment or brush to clean.

2. Clean the water bucket

Every few weeks, clean the water bucket to prevent growth of mould, mildew and bacteria. Partially fill the bucket with clean water and add a little mild detergent. Swish it around to clean then empty and rinse.

NOTE: Do not place the bucket in a dishwasher.

3. Clean the washable nylon air filter

The air filter (Fig. 9b) should be checked and cleaned at least every 30 days or more often if necessary.

To remove the filter:

- Grip the tab on the bottom the filter housing and pull it upward, then pull it out and down as shown in Fig.9a.
- Clean the filter with warm, soapy water. Rinse and let the filter dry before replacing it. Do not clean the filter in a dishwasher.

To replace the filter:

Insert the air filter into the unit locating the top lugs first then pushing the bottom in. Make sure the removable filter is pushed up behind the outer grille or it may stop the outer grille clipping in properly. See Fig.9c.

CAUTION:

- DO NOT operate the dehumidifier without a filter because dirt and lint will clog it and reduce performance.

4. When not using the unit for long periods:

- After turning off the unit, wait 24 hours before emptying the tank to allow any residual water to drain down.
- Clean the main unit and air filter and wipe dry inside the bucket
- Store the unit upright in a dry, well-ventilated place.

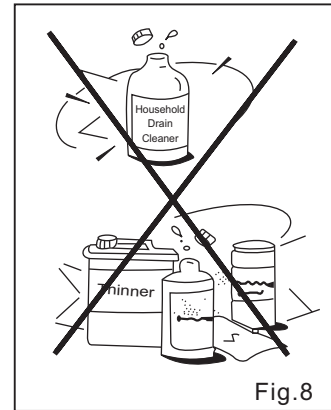

Fig.8

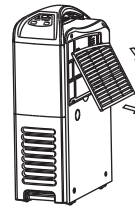

Fig.9a



Fig.9b

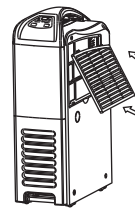

Fig.9c

Optional Filter - HEPA or Carbon Filter

This appliance is supplied with a HEPA Filter.

It is recommended that the HEPA Filter is replaced every 6 - 12 months depending on frequency of usage. You may replace it with a Carbon Filter instead.

Replacement HEPA or Carbon Filter can be purchased directly from EcoAir. Please contact 020 8459 2458. The HEPA or Carbon Filter is optional but the washable nylon filter must always be used.

To replace the HEPA or Carbon filter :-

- First remove the washable nylon air filter (Fig. 10a)
- Remove the HEPA filter from the frame (behind the air filter)
- Insert the HEPA or Carbon filter within the lugs around the frame (Fig. 10c)
- Refit the nylon air filter

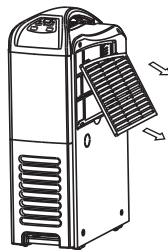

Remove nylon air filter

Fig. 10a

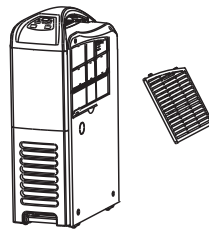

Reveal the frame
for optional filters

Fig. 10b

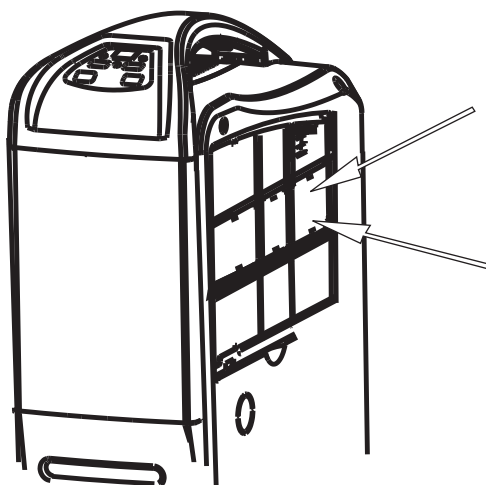

Frame for optional
filters (HEPA / Carbon)

Fig.10c

TROUBLESHOOTING TIPS

Problem	What to check
Unit does not start	<ul style="list-style-type: none">● Make sure the dehumidifier's power plug is pushed completely into the mains socket and is switched on.● Check the house fuse/circuit breaker box.● Dehumidifier has reached its preset humidity level.● Tank is full or not in the proper position.
Dehumidifier does not dry the air as it should	<ul style="list-style-type: none">● Allow enough time for the machine to remove the moisture.● Make sure there are no curtains, blinds or furniture blocking the front or back of the dehumidifier.● The humidity control may not be set low enough.● Check that doors, windows and other openings are closed to minimise the volume of air the unit has to dehumidify.● Room temperature is too low, below 5°C(41°F).● There is a gas heater, a fish tank or something giving off water vapour in the room.
The unit makes a loud noise when operating	<ul style="list-style-type: none">● The air filter is clogged.● The unit is tilted instead of upright as it should be.● The floor surface is not level or is unsupported causing resonance.
Frost appears on the coils	<ul style="list-style-type: none">● This is normal. The dehumidifier has Auto defrost feature.
Water on the floor	<ul style="list-style-type: none">● Unit is not level so water spilling over edge of bucket.● Continuous drain hose is not fitted correctly to nozzle or is not draining downhill correctly.● Intended to use bucket to collect water but the back of drain hose is removed.
E1, E2, P1 or P2 appear in the display	<ul style="list-style-type: none">● These are error codes and not necessarily a fault with the machine. See PAGE 4 for details.

ONE (1) YEAR LIMITED WARRANTY
Save This Warranty Information

EcoAir guarantees this product free from defects in materials and workmanship for a period of one (1) year from the date of purchase.

This unit must be operated under conditions as recommended, at voltages indicated on the unit. Any attempts made to service or modify the unit, will render this **WARRANTY VOID**. The actual product may differ slightly from the illustration. This warranty is in addition to, and does not affect, your statutory rights.

For further information, please contact 020 8459 2458.

This product has been manufactured to comply with the EEC Directives 73/23/EEC and 89/336/EEC.